



## ■ Description

MT6705 is a high performance 45V synchronous rectifier series product for Flyback converters. It is compatible with various Flyback converters types. It supports DCM, CCM and Quasi-Resonant.

It integrates a 45V power MOSFET that can replace Schottky diode for high efficiency.

It turns on the internal MOSFET if the  $V_{SW} < V_{TH-ON}$  and turns it off the internal MOSFET if the  $V_{SW} > V_{TH-OFF}$ .

It don't need external power supply, and it supports High-side and Low-side Rectification.

It Integrated with intelligent turning on detection function, it can effectively prevent the misjudge of MOSFET caused by  $V_{DS}$  oscillation in DCM and improve system efficiency and reliability

## ■ Feature

- Supports DCM, CCM and QR Flyback converter
- Supports High-side and Low-side Rectification
- NO need external power supply
- Integrated 45V Power MOSFET
- Advanced rectifier turn on technology
- VCC UVLO, VCC Clamp
- Available SOP-8 Package

## ■ Applications

- Mobile Phone Chargers
- Flyback converters
- AC - DC adapter

## ■ Typical Application

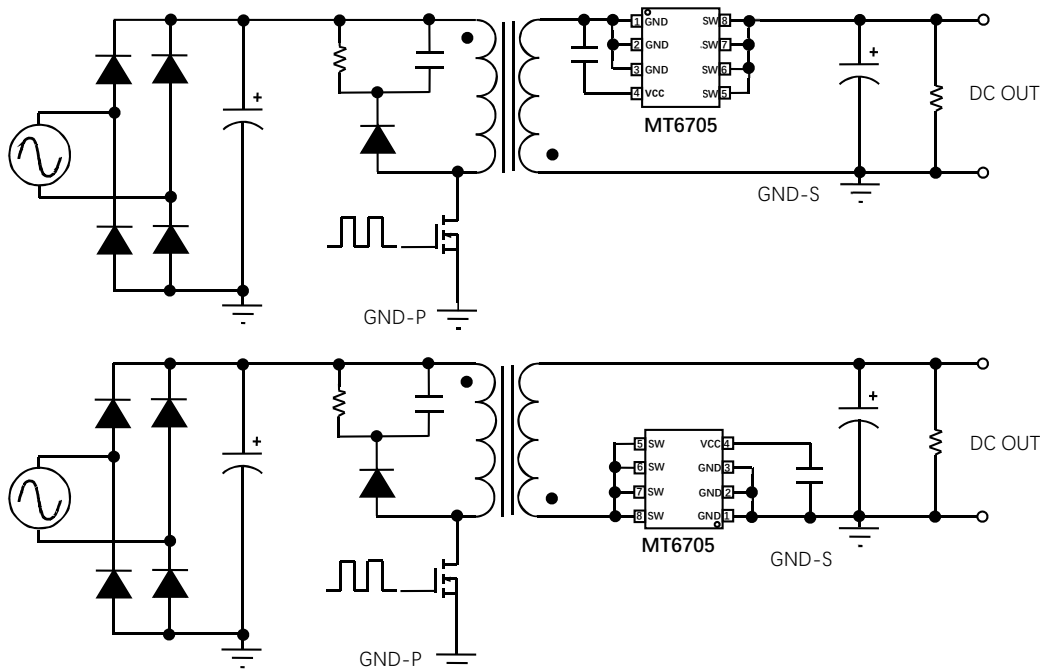

Figure 1 : MT6705 Typical Application



## General Information

### Pin Configuration

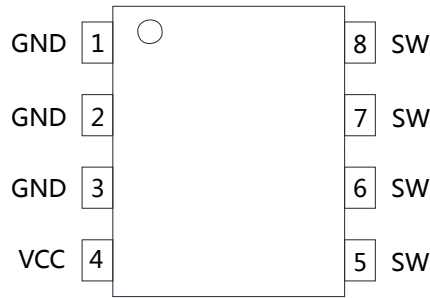
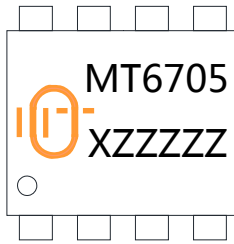

Figure 2 : MT6705 Pin configuration

### TERMINAL ASSIGNMENTS

PIN	NAME	DESCRIPTION
1, 2, 3	GND	IC ground and source of integrated MOSFET
4	VCC	IC power supply pin
5, 6, 7, 8	SW	Voltage detection and drain of integrated MOSFET

### Marking Information



MT6705: Product Model

X	Product Code
A	MT6705A
B	MT6705B
C	MT6705C

ZZZZZ: Lot Code

### Ordering Information

Part Number	DESCRIPTION
MT6705A	SOP8, Green ,T&R
MT6705B	SOP8, Green ,T&R
MT6705C	SOP8, Green ,T&R

### Application information Sheet

Part Number	R <sub>DS(ON)</sub> (mΩ)
MT6705A	20
MT6705B	16
MT6705C	10

## Absolute Maximum Ratings (note 1)

Description	Symbol	Parameter Scope	Unit
VCC PIN	V <sub>CC</sub>	-0.3 to 7	V
SW PIN	V <sub>SW</sub>	-0.3 to 45	V
The power dissipation	P <sub>DMAX</sub>	0.45	W
Maximum Junction Temperature	T <sub>J</sub>	150	°C
Storage Temperature Range	T <sub>ST</sub>	-65 to 150	°C
Junction-to-ambient thermal resistance	R <sub>θJA</sub>	96	°C/W
Junction-to-case(top) thermal resistance	R <sub>θJC</sub>	45	°C/W
Lead Temperature (Soldering,10sec)	T <sub>LEAD</sub>	260	°C
ESD Capability,HBM	ESD <sub>HBM</sub>	2000	V
ESD Capability,MM	ESD <sub>MM</sub>	250	V

### RECOMMENDED OPERATING CONDITIONS (Note2)

Description	Symbol	Parameter Scope	Unit
Supply Voltage	V <sub>CC</sub>	4.8 to 5.6	V
Operating Junction Temperature	T <sub>OJ</sub>	-40 to 125	°C
Maximum Output Power	P <sub>O-MAX</sub>	MT6705A	10.0(5V/2.0A)
		MT6705B	12.0(5V/2.4A)
		MT6705C	15.0(5V/3.0A)

**Note1** : Stresses beyond those listed under "absolute maximum ratings" may cause permanent damage to the device

**Note2** : The device is not guaranteed to function outside its operating conditions.



■ ELECTRICAL CHARACTERISTICS (Unless otherwise specified,  $T_a=25\text{ }^\circ\text{C}$ )

PARAMETER	Symbol	Conditions	Min	Typ	Max	Units
SUPPLY						
VCC Operation Voltage	$V_{CC}$	SW=30V, $V_{CC}=100\text{nF}$	4.8		5.6	
VCC Under Voltage Lockout Exit	$V_{ST}$	$V_{CC}$ Rising	3.3	3.7	4.0	V
VCC Under Voltage Lockout	$V_{UVLO}$	$V_{CC}$ Falling	2.0	2.5	3.0	V
VCC Clamp Voltage	$V_{CLAMP}$	$I_{CC}=10\text{mA}$	5.7	6.0	6.5	V
VCC Start up Current	$I_{ST}$	$V_{CC}=V_{ST}-1\text{V}$			1	$\mu\text{A}$
Operation Current	$I_Q$	$V_{CC}=5\text{V}$ , $V_{CC}=100\text{nF}$	140	200	320	$\mu\text{A}$
SW ON						
Turn On Threshold Voltage	$V_{TH-ON}$	$V_{SW}$ Falling	-250	-200	-150	mV
Turn Off Minimum time	$T_{MIN-OFF}$			500		ns
Maximum Turn on detection slope	$K_{max}$	$V_{CC}=5.0\text{V}$	18.4	20	25	V/100ns
Minimum Turn on detection slope	$K_{max}$	$V_{CC}=5.0\text{V}$	1.2	1.5	1.8	V/100ns
SW OFF						
Turn Off Threshold Voltage	$V_{TH-OFF}$	$V_{SW}$ Rising	-10	-5	-2	mV
Turn On Minimum time	$T_{MIN-ON}$			1.2		ns
Turn Off Delay time	$T_D$		25	30	35	ns
Power MOS reverse recovery time	$T_{RR}$				30	ns
Power MOS						
Internal MOS $R_{DS(ON)}$	$R_{DS(ON)}$	MT6705A	$V_{GS}=4.5\text{V}$ , $I_{SW}=10\text{A}$		20	$\text{m}\Omega$
		MT6705B	$V_{GS}=4.5\text{V}$ , $I_{SW}=16\text{A}$		16	$\text{m}\Omega$
		MT6705C	$V_{GS}=4.5\text{V}$ , $I_{SW}=20\text{A}$		10	$\text{m}\Omega$
Drain-to-Source Breakdown Voltage	$BV_{DSS}$	MT6705A	$V_{GS}=0\text{V}$ , $I_{SW}=250\mu\text{A}$	45		V
		MT6705B	$V_{GS}=0\text{V}$ , $I_{SW}=250\mu\text{A}$	45		V
		MT6705C	$V_{GS}=0\text{V}$ , $I_{SW}=250\mu\text{A}$	45		V

■ Internal Block Diagram

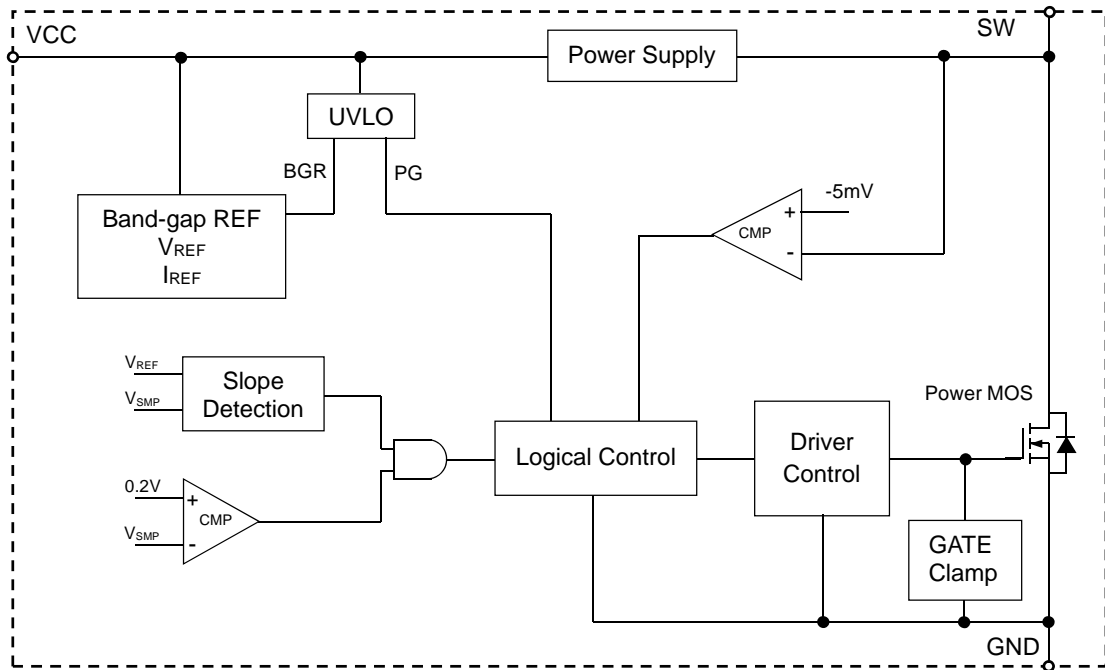

Figure 3: MT6705 Block Diagram



## ■ Functional Description

### Operation

MT6705 is a synchronous rectifier, it can replace the Schottky to improve the efficiency in Flyback converters. It supports operation in DCM,CCM and Quasi-Resonant Flyback converters.It can power itself through the internal LDO during the turn-off period, a 100nF capacitor is needed between VCC and GND.

### Startup

During the startup period, when the VCC is lower than startup voltage, the internal MOSFET is turned off. The current flows through body diode until the VCC exceeds the startup voltage.

### Turn-on Blanking Time

The control circuitry contains a blanking function.When the internal MOSFET is turned on, it at least last for some time, the turn on blanking time is about 1.2uS. During the turn on blanking period, the turn off threshold is not totally blanked, but changes the threshold current. This assures that the internal MOSFET can always be turned off even during the blanking period.

### Under-Voltage Lockout (UVLO)

When the VCC is below UVLO threshold, the internal MOSFET is turned off and never turned on before the VCC exceeds the startup voltage.

### Turn On Phase

The switch current first flows through the body diode of integrate MOSFET, which generates a negative  $V_{SW}$ . When the  $V_{SW}$  is lower than  $-0.2V$  and then  $V_{SW}$  is lower than  $V_{TH-ON}$ , it turns on the integrate MOSFET.

### Turn Off Phase

The MT6705 senses the current of the internal MOSFET  $I_{SW}$ , before  $I_{SW}$  is lower than Internal MOS turn off threshold, the driver voltage of the switch is pulled down to zero after 30ns delay.

### Slope Detection

When working in DCM mode, due to the excitation of the leakage inductance, when the primary chip is turned off, there will be oscillation. In order to prevent the abnormal opening of the synchronous rectifier caused by the false detection of oscillating signals, MT6705 adopts the patented rectifier opening technology. When the primary chip is turned off, the voltage between drain SW and GND of the secondary MT6705 drops rapidly.

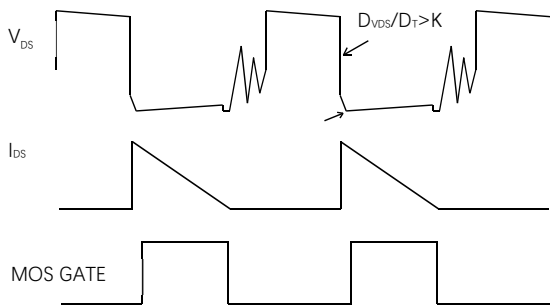

Figure 4 Secondary waveform

$$K = \frac{282 - 56.3t}{14.2 - 0.014T} (V/100nS)$$

K : Turn on Slope Detection

T : chip Junction Temp

t : V<sub>DS</sub> duration greater than 4V, t ≤ 4.7, when the timing is greater than 4.7, take 4.7, unit us; Reset less than 4V restarts from zero.

### RC Snubber Circuit

In some applications (output short circuit protection), the inductor current may go into slight CCM condition. To avoid the voltage

spike across the synchronous rectifier, we suggest RC snubber should be placed between SW and GND, and a resistor should be paralleled with VCC capacitor.

### PCB Layout

The following rules should be followed in MT6705 PCB layout:

**VCC capacitor:** The VCC pin must be locally bypassed with a capacitor. Capacitance as close as possible to VCC-pin.

**The Area of Power Loop:** The area of the main current loop should be as small as possible to reduce EMI radiation, such as the snubber circuit and the secondary rectifying loop.

**SW and GND Pin:** SW pin increases the copper area of the drain terminal for heat dissipation. And the PCB trace of SW and GND must be wide and short for thermal consideration. However too large copper area may compromise EMI performance.



**PACKAGING INFORMATION & MECHANICAL DATA**

Orderable Device	Package Type	Package Qty	Eco Plan	Lead/Ball Finish	MSL Peak Temp	Op Temp (°C)	Device Marking
MT6705A	SOP8	4000	Green (RoHS& no Sb/Br)	Matte Tin	Level-3-260C-168 HR	-40 to 125	MT6705 AXXXXXX
MT6705B	SOP8	4000	Green (RoHS& no Sb/Br)	Matte Tin	Level-3-260C-168 HR	-40 to 125	MT6705 BXXXXXX
MT6705C	SOP8	4000	Green (RoHS& no Sb/Br)	Matte Tin	Level-3-260C-168 HR	-40 to 125	MT6705 CXXXXXX

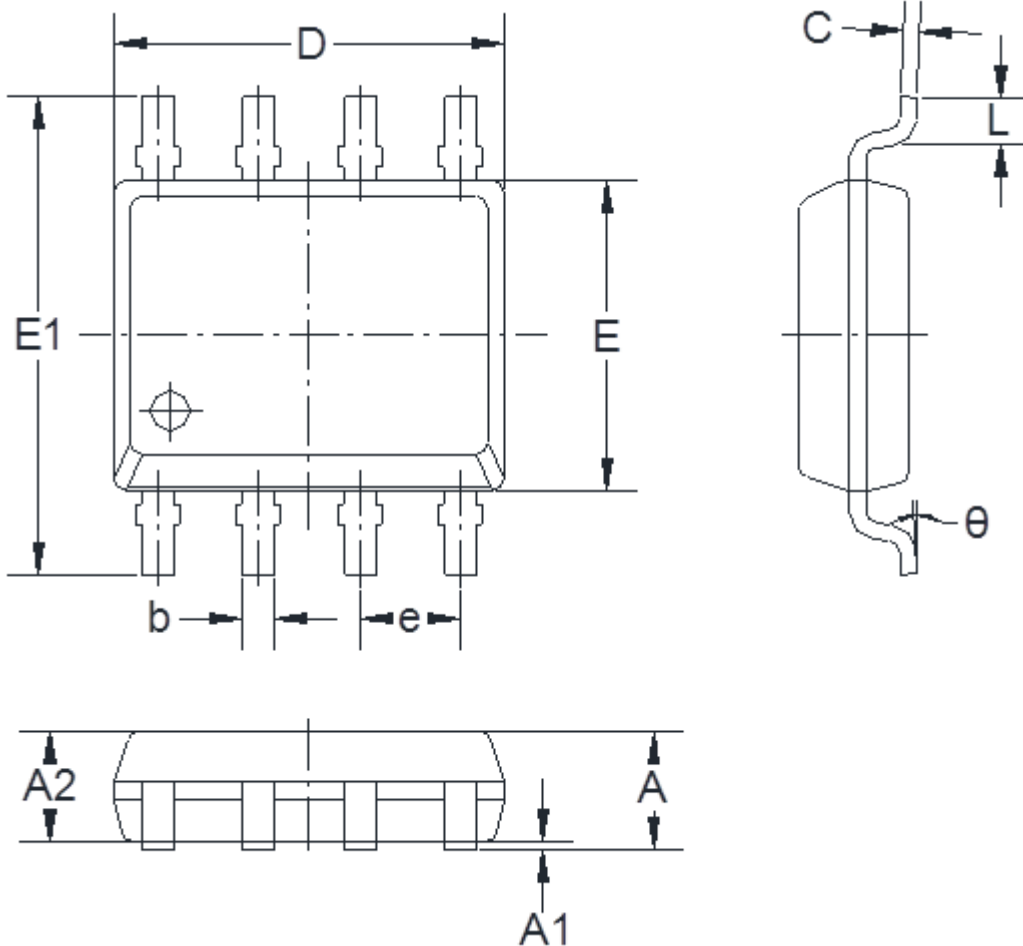

Symbol	Dimensions In Millimeters		Dimensions In Inches	
	Max	Min	Max	Min
A	1.350	1.750	0.053	0.069
A1	0.050	0.250	0.002	0.010
A2	1.250	1.650	0.049	0.065
b	0.310	0.510	0.012	0.020
c	0.170	0.250	0.006	0.010
D	4.700	5.150	0.185	0.203
E	3.800	4.000	0.150	0.157
E1	5.800	6.200	0.228	0.244
e	1.270 (BSC)		0.05 (BSC)	
L	0.400	1.270	0.016	0.050
theta	0°	8°	0°	8°



## IMPORTANT NOTICE

### RIGHT TO MAKE CHANGES

Xingjingtai Technology Corp. reserves the right to make corrections, modifications, enhancements, improvements and other changes to its products and services at any time and to discontinue any product or service without notice. Customers should obtain the latest relevant information before placing orders and should verify that such information is current and complete.

### WARRANTY INFORMATION

Xingjingtai Technology Corp. warrants performance of its hardware products to the specifications applicable at the time of sale in accordance with its standard warranty. Testing and other quality control techniques are used to the extent it deems necessary to support this warranty. Except where mandated by government requirements, testing of all parameters of each product is not necessarily performed. Xingjingtai Technology Corp. assumes no liability for application assistance or customer product design. Customers are responsible for their products and applications using Xingjingtai's components, data sheet and application notes. To minimize the risks associated with customer products and applications, customers should provide adequate design and operating safeguards.

### LIFE SUPPORT

Xingjingtai Technology Corp.'s products are not designed to be used as components in devices intended to support or sustain human life. Xingjingtai Technology Corp. will not be held liable for any damages or claims resulting from the use of its products in medical applications.

### MILITARY

Xingjingtai Technology Corp.'s products are not designed for use in military applications. Xingjingtai Technology Corp. will not be held liable for any damages or claims resulting from the use of its products in military applications.